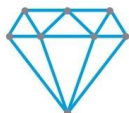
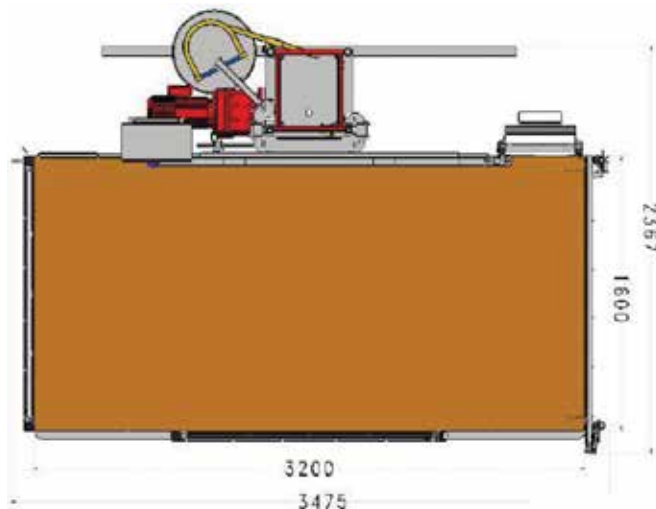
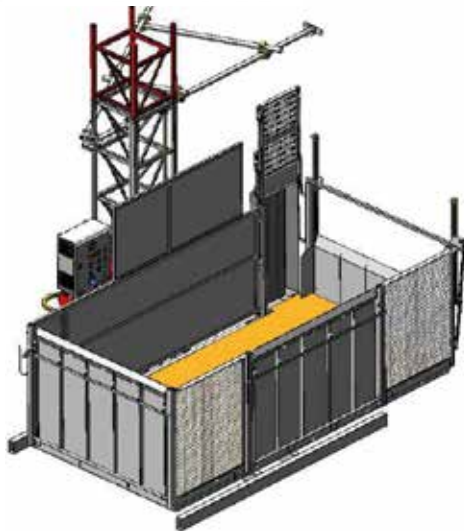

PT1600L

**DIAMANTE  
PONTEGGI**

DATI TECNICI	TECHNICAL DATA	DONNEES TECHNIQUES	PT 1600 L TRIFASE	PT 1600 L TRIFASE TD
Capacità di carico	Payload capacity	Charge nominale	1400 kg	1400 kg
Velocità di sollevamento	Lifting speed	Vitesse de lévage	12 m/min	12 m/min tp mode 24 m/min mh mode
Massima altezza ancorata	Max height with tied must	Hauter max avec ancrages	120 m	120 m
Dimensioni interne cesta	Internal platform dimensions	Dimensions du plancher	3,2 x 1,6 m	3,2 x 1,6 m
Tensione alimentazione	Power supply	Tension d'alimentation	400 V 50 Hz	400 V 50 Hz
Potenza motori	Engines power	Puissance du moteurs	2 x 4 kW	2 X 5.5 kW
Minima potenza di linea consigliata	Minimum recommended line power	Puissance de ligne minimale recommandée	8 kW	12 kW
Peso unità di base	Base unit weight	Poids unité de base	1350 kg	1350 kg